

TEST REPORT # 2012059-2

**SnapLock
Fixed Security Window Grille (Large Diamond)
Sample Number – 145984-10**

FOR

Prowler Proof



**NATA Accredited Laboratory
Number: 14426**

**Accredited for compliance with ISO/IEC
17025**

Date of issue: 12/09/2012

**Test Report
Security Window Grille**

Test Report Number:	2012059-2	Project Number:	10541
Manufactured By:	Prowler Proof	Date of Submission:	09/09/2012
Tested By:	C Horton	Date Tested:	09/09/2012
Certified By:	A Sterrenberg		
Witnessed By:	Michael Henry – Prowler Proof		

Details of Test Window

Type and Class:	Type 1 Class A
Make or Model:	SnapLock - Large Diamond
Sample Number:	145984-10
Frame Size:	1500mm x 900mm
Framing Material:	Pinus Radiata – 70mm x 35mm
Constructional Description of Test Security Window Grille:	
Fixed security window grille with infill secured utilising Prowler Proof SnapLock method. Frame corners welded.	

Details of Test Window Infill

Type and Fabrication Method:	Extruded and expanded aluminium diamond grille.
Manufacturer's Name / Part Number:	Prowler Proof - PPLD127
<u>Type 1 Mesh Infill (if applicable)</u>	
1) Number of Intersected Strands in a 150mm Circle:	8
2) Breaking Force in Shear of One Strand (min 3kN):	4.93
3) Multiplication of Above Points 1 and 2 (min 30kN):	39.50

(Above details supplied by customer not by testing authority)

Test Report Security Window Grille

Dynamic Impact Test – AS 5039/5041

Measurement Before Impact Test at Impact Point (datum reading):			
Test	Remarks	Pass	Fail
Impact One:	Grille secure in frame.	Ü	
Impact Two:	Grille secure in frame.	Ü	
Impact Three:	Grille secure in frame.	Ü	
Impact Four:	Grille secure in frame.	Ü	
Impact Five:	Grille secure in frame.	Ü	
150mm Diameter Probe test using R.M.F:	-	Ü	
65mm Probe check:	-	Ü	

Jemmy Tests – AS 5039/5041

Location	Remarks	Pass	Fail
Centre Locking Point:	No gap arose to allow for jemmy tests - Pass		
Bottom Locking Point:			
Top Locking Point:			
Centre Hinge:			
Bottom Hinge			
Top Hinge:			

Infill Pull Tests – AS 5039/5041

Location	A 450mm Maximum	B 150mm Maximum	C 100x100mm Maximum	D	E	Pass	Fail
Centre Grille (1.5kN):	Ü	Ü	Ü	Ü	Ü	Ü	
Top Corner, Lock Side (1.5kN):	Ü	Ü	Ü	Ü	Ü	Ü	
Bottom Corner, Lock Side (1.5kN):	Ü	Ü	Ü	Ü	Ü	Ü	

A - Maximum size of any gap between grille and grille frame or grille frame and door frame under load (dynamic).

B - Maximum size of any gap between grille and grille frame or grille frame and door frame after load (static).

C - The size of any gap caused by the infill breaking away from the security grille framing.

D - Whether the grille remained in a fixed position.

E - Whether the locking device maintained the door in a locked position.

Overall Test **Pass**

Remarks:

Impact test - Pass

Jemmy test - Pass

Pull test - Pass

This signature indicates that testing has been conducted in accordance to the current AS 5039-2003, and test results reflect the test findings.

Authorised Signature

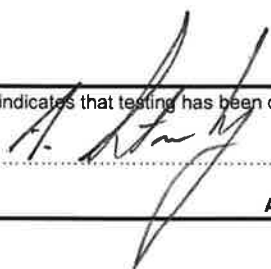

Print Name

A. Sterrenberg

Date

12/09/12

Accredited for compliance with ISO/IEC 17025

Identification Details for Security Window Grille
Submitted for Type Testing in Accordance to AS 5039/5041
(Informative)

General

Model Number / Name:	SnapLock LD
Sample Number:	145984-10
Manufactured By:	Gershwin Pty Ltd trading as Prowler Proof
Date of Submission:	11/09/12
Description:	Fixed security screen window
DRAWINGS: COMPLETE ATTACHED SHEETS	
(To show additional specific details of door construction such as internal stiffening, hinging, etc., attach further sheets as necessary)	

Framing Section

Type:	Extruded aluminium		
Manufacturer's-	Name: Prowler Proof	Section Number:	SLW11
Attached Dimensional Drawing-	Number: -	Issue:	-
Material Type and Grade:	Aluminium 6060-T5		
Surface Finish:	Powder coated		
Mass per Metre Length (kg):	-		
Mounting Frame Material:	See attached CAD drawings		
(Attach drawings if necessary)			

Corner Stake – NA Welded Corners

Infill

Type and Fabrication Method:	Large Diamond Grille				
Manufacturer's-	Name: Prowler Proof	Part Number:	PPLD127		
Attached Dimensional Drawing-	Number: -	Issue:	-		
Material Type and Grade:	Aluminium 6063-T5				
Surface Finish:	Anodised				
Diameter of Type 3 Infill:	See attached				
Means of Securing:	<input type="checkbox"/> Weld	<input type="checkbox"/> Screw	<input type="checkbox"/> Rivet	<input type="checkbox"/> Other	<input type="checkbox"/> ũ
(If means of securing is OTHER, submit full details on a separate sheet)					

Fastener Details:

Type:	Clamp and bonded – Every contact point		Part Number:	SL Clamp		
Material	<input type="checkbox"/> Alum	<input type="checkbox"/> St.Steel	<input type="checkbox"/> Monel	<input type="checkbox"/> Steel	<input type="checkbox"/> OTHER	<input type="checkbox"/> ũ
Number Used and Location:	See attached – Clamp and bond – Full perimeter					
(Attach drawings if necessary)						

Manufactured By: Prowler Proof

Sample Number: 145984-10

Location of Fixing Points, Locking Points, Hinges and Mid-Rail – Refer attached CAD drawing SSLD - Testing Sample

Means of Securing Infill to Framing, Location of Welds / Fasteners - Refer attached CAD drawing SSLD – Snaplock Large Diamond Window

End

BILL OF MATERIALS

ITEM	QTY	DESCRIPTION	STOCK NO./DESC.	MATERIAL	LENGTH	WIDTH
1	1	WINDOW TIMBER - TEST FRAME	AS5039-SLLD FW2004			
2	1	SLLD - SnapLock Large Dimond Window	AS5039-SLLD FW2001			
3	20	ASSY-Pan Head AW20 4.5x40mm	100642	Mild Steel		

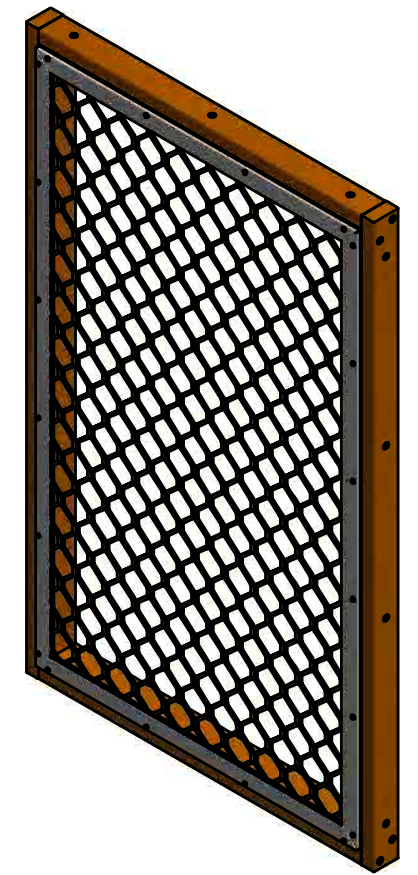
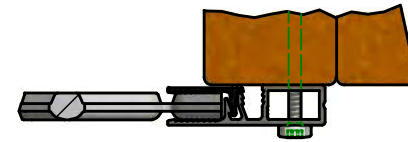
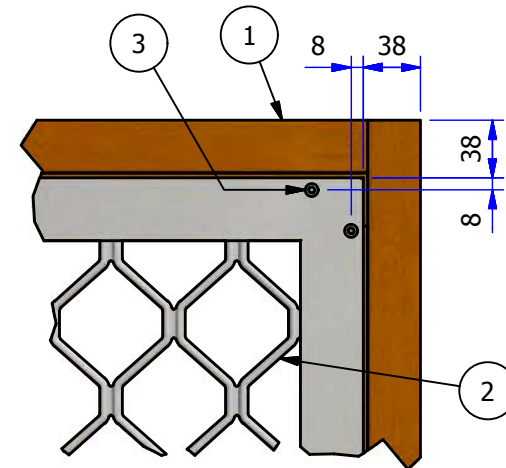
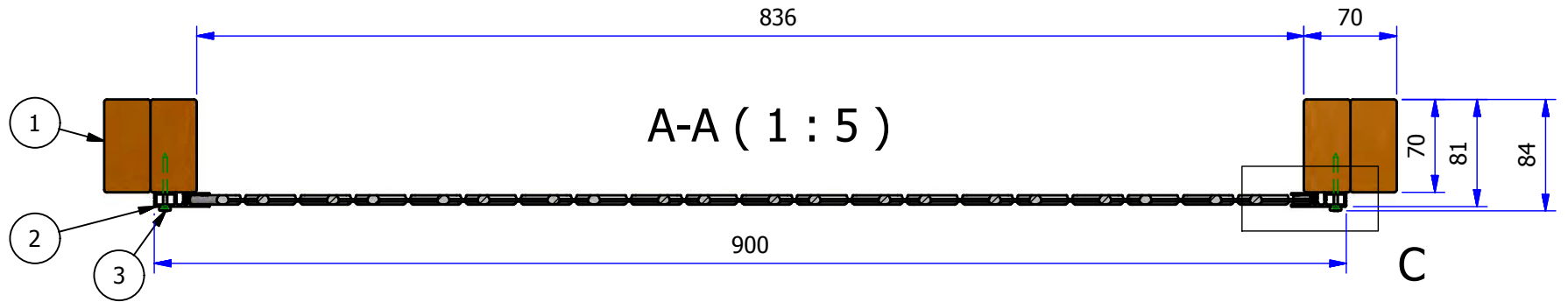
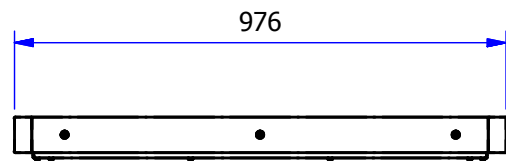

ISOMETRIC VIEW

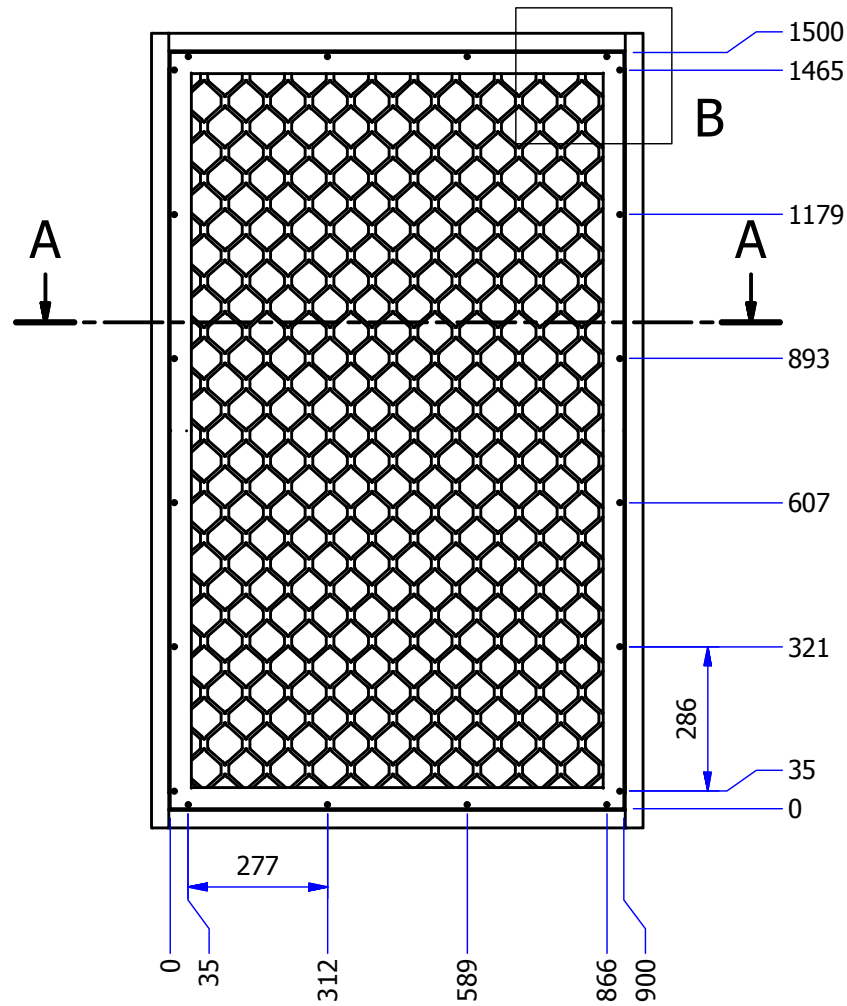
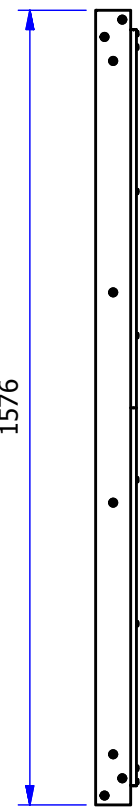

FRONT VIEW 1 (1 : 15)

Prowler Proof

GERSHWIN PTY LTD
 122 BUCHANAN RD
 BANYO, QLD. 4014
 PH: +61 7 3363 0666
 FAX: +61 7 3267 5411

DRAWN CAD	DATE 11/11/2012	TITLE: AS5039 - Testing		PROCESS CODE:
CHECKED	DATE	SLLD - Testing Sample		SHEET 1 OF 1
APPR.	DATE	PART NUMBER: AS5039-SLLD FW1000	DRAWING DOCUMENT FILE NAME: AS5039-SLLD FW1000.idw	SCALE NTS
RAW MATERIAL	MATERIAL THICKNESS	MODEL DOCUMENT FILE NAME: AS5039-SLLD FW1000.iam	STOCK NUMBER / DESCRIPTION	REV.

* THIS DRAWING AND ITS CONTENTS ARE CONFIDENTIAL AND ARE SUBJECT TO RETURN ON DEMAND AND MAY NOT BE COPIED OR DISCLOSED TO ANY THIRD PARTY OR USED DIRECTLY OR INDIRECTLY FOR ANY OTHER PURPOSE THAN AS EXPRESSLY DETERMINED IN WRITING BY Gershwin Pty. Ltd.

UNLESS OTHERWISE SPECIFIED
 XX = ± 1mm
 X.X = ± 0.5mm
 XX.XX = ± 0.25mm

MACHINE FINISHES = 3.2
 ALL DIMENSIONS IN MILLIMETERS
 ALL THREAD TO BE METRIC COARSE
 ALL WELDS TO AS1554
 ALL BURRS AND SHARP EDGES TO BE REMOVED

PROJECTION
 3RD ANGLE

DO NOT SCALE DRAWING

WEIGHT: 19.40 kg

SHEET SIZE: A3 INV.

REV. No	REVISION DESCRIPTION	DRAWN	DATE	APP. BY	DATE
1	REVISION HISTORY				

BILL OF MATERIALS

ITEM	QTY	DESCRIPTION	STOCK NO./DESC.	MATERIAL	LENGTH	WIDTH
1	1	LD 1250x2450 MF	102561	AL 6063 T5	1446	846
2	4	SL Clamp - 3000mm - Black	100039	AI 6060 T5		
3	4	SLW11 5800mm MF	100037	AI 6060 T5		

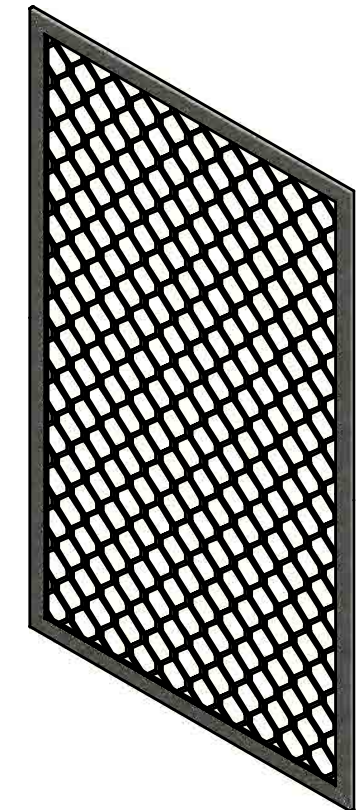
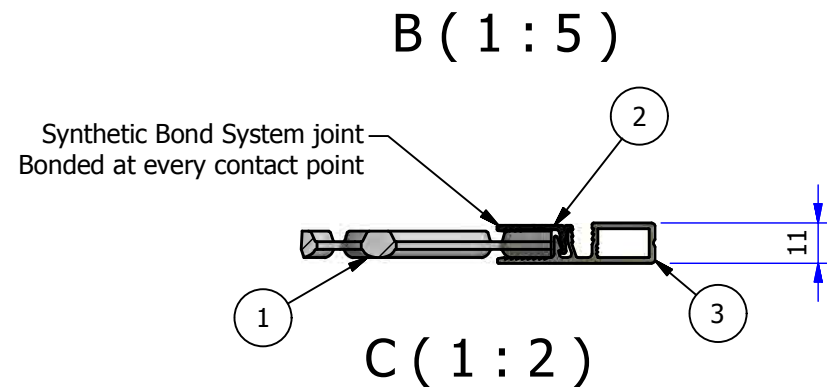
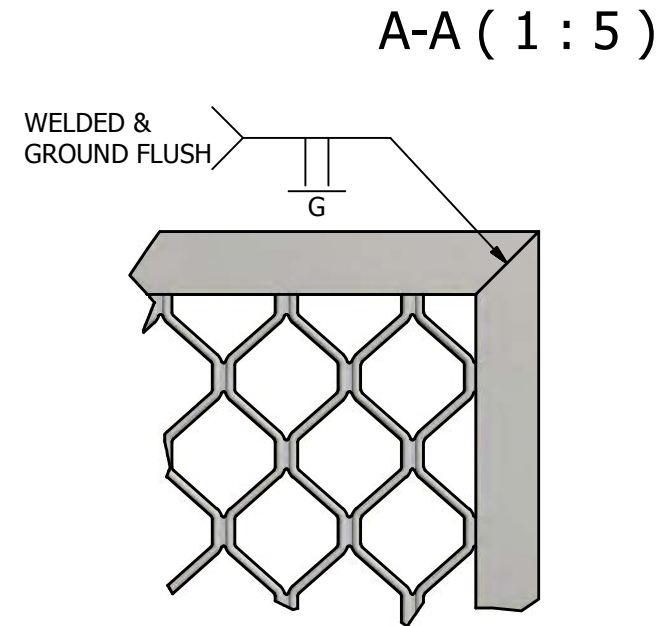
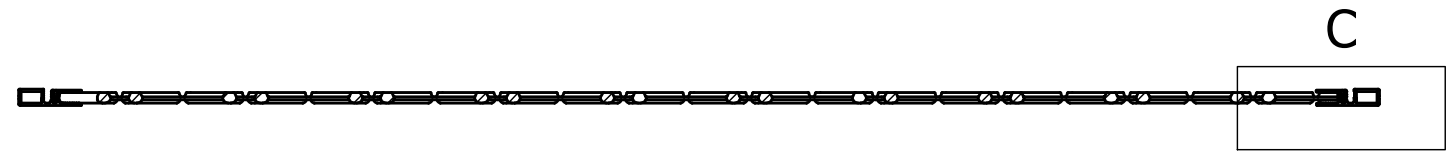
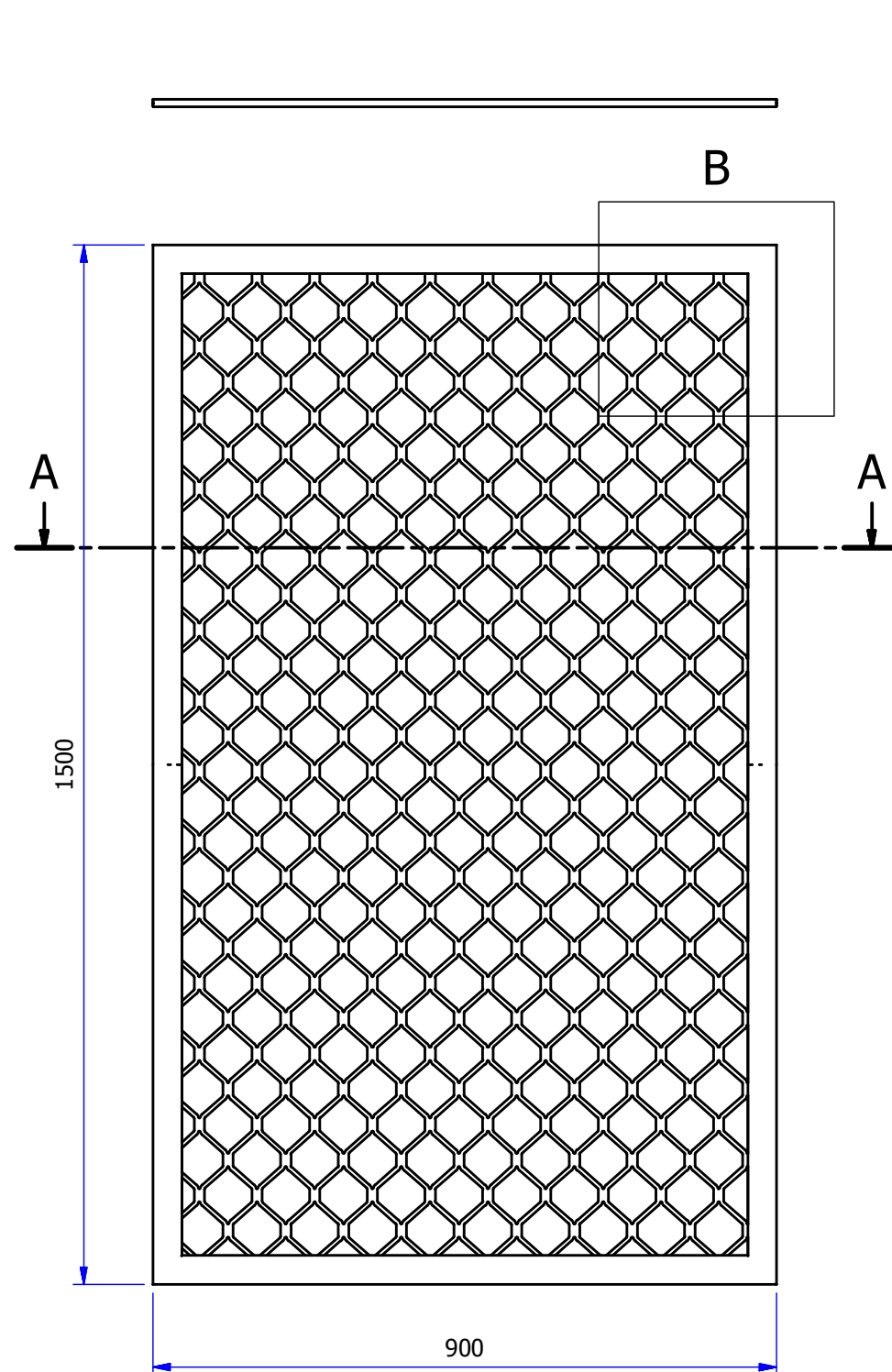

<p>Prowler Proof</p> <p>GERSHWIN PTY LTD</p> <p>122 BUCHANAN RD</p> <p>BANYO, QLD. 4014</p> <p>PH: +61 7 3363 0666</p> <p>FAX: +61 7 3267 5411</p>	DRAWN	DATE	TITLE:	PROCESS CODE:												
	CAD	11/11/2012	AS5039 - Testing	SHEET												
	CHECKED	DATE	SLLD - SnapLock Large Dimond Window	1 OF 1												
	APPR.	DATE	PART NUMBER:	SCALE												
		AS5039-SLLD FW2001	NTS	REV.												
RAW MATERIAL	MATERIAL THICKNESS	STOCK NUMBER / DESCRIPTION	AS5039-SLLD FW2001													
<p>• THIS DRAWING AND ITS CONTENTS ARE CONFIDENTIAL AND ARE SUBJECT TO RETURN ON DEMAND AND MAY NOT BE COPIED OR DISCLOSED TO ANY THIRD PARTY OR USED DIRECTLY OR INDIRECTLY FOR ANY OTHER PURPOSE THAN AS EXPRESSLY DETERMINED IN WRITING BY Gershwin Pty. Ltd.</p>		<p>UNLESS OTHERWISE SPECIFIED</p> <p>XX = • 4mm MACHINE FINISHES = 3.2</p> <p>X.X = • 0.5mm</p> <p>XX.XX = • 0.25mm</p> <p>DO NOT SCALE DRAWING</p>		<p>ALL DIMENSIONS IN MILLIMETERS</p> <p>ALL THREAD TO BE METRIC COARSE</p> <p>ALL WELDS TO AS1554</p> <p>ALL BURRS AND SHARP EDGES TO BE REMOVED</p>												
<p>REVISION HISTORY</p> <table border="1"> <thead> <tr> <th>REV. No</th> <th>REVISION DESCRIPTION</th> <th>DRAWN</th> <th>DATE</th> <th>APP. BY</th> <th>DATE</th> </tr> </thead> <tbody> <tr> <td>1</td> <td></td> <td></td> <td></td> <td></td> <td></td> </tr> </tbody> </table>		REV. No	REVISION DESCRIPTION	DRAWN	DATE	APP. BY	DATE	1						<p>PROJECTION 3RD ANGLE</p> <p>WEIGHT: 5.61 kg</p> <p>SHEET SIZE: A3</p>		<p>INV.</p>
REV. No	REVISION DESCRIPTION	DRAWN	DATE	APP. BY	DATE											
1																

BILL OF MATERIALS

ITEM	QTY	DESCRIPTION	STOCK NO./DESC.	MATERIAL	LENGTH	WIDTH
1	2	Radiata Pine - MGP15 Stud 70x35		Pine	836	35
2	2	Radiata Pine - MGP15 Stud 70x35		Pine	1576	35
3	2	Radiata Pine - MGP15 Stud 70x35		Pine	1506	35
4	2	Radiata Pine - MGP15 Stud 70x35		Pine	906	35
5	14	Bugle Head Batten Screw 14gx50mm		Steel, Mild	50	
6	8	Bugle Head Batten Screw 14gx100mm		Steel, Mild	100	

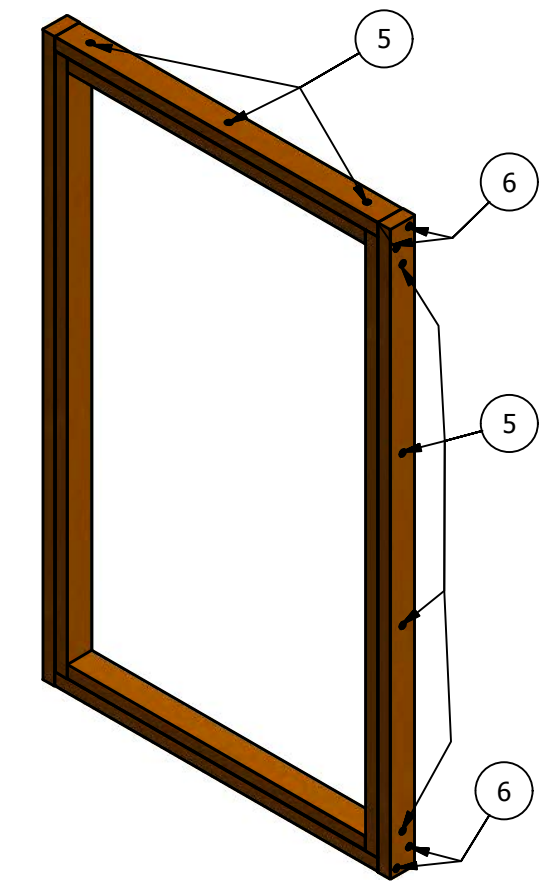
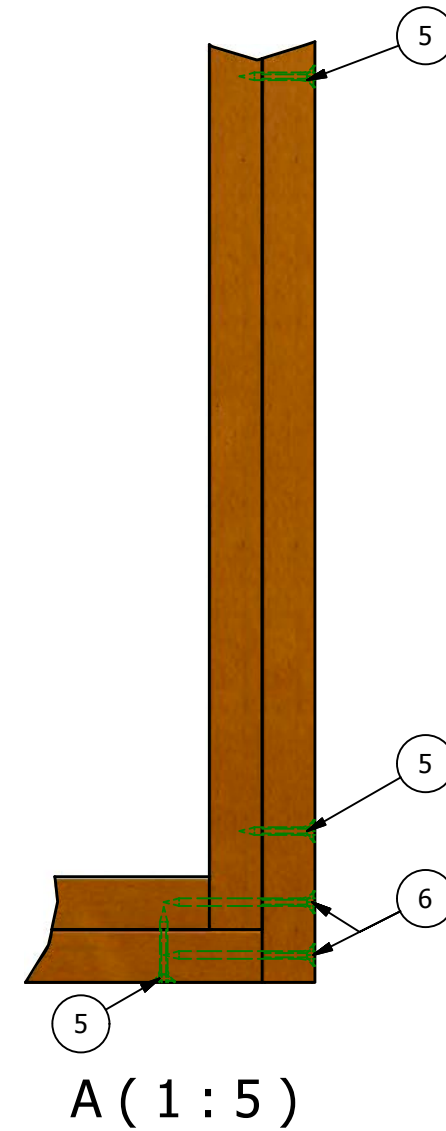
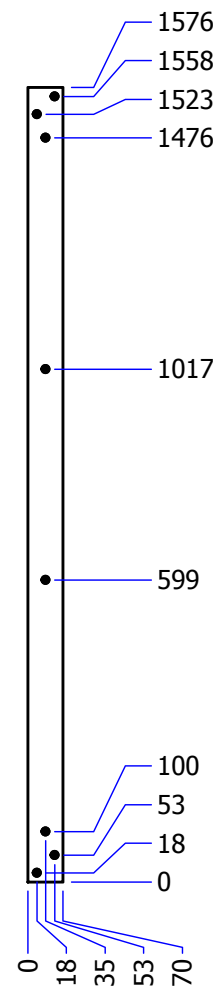
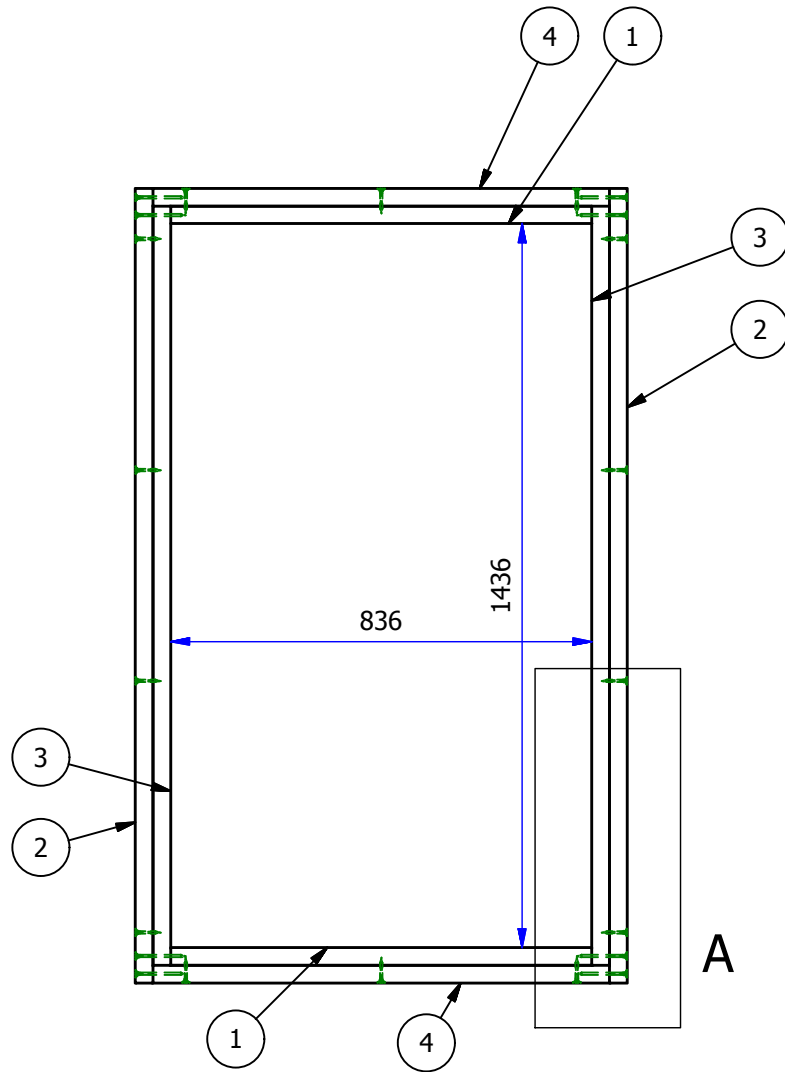
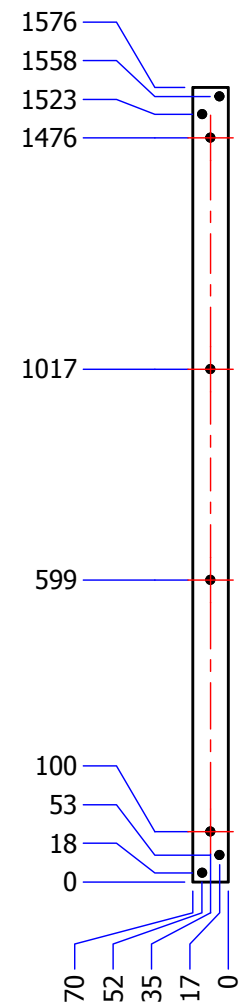
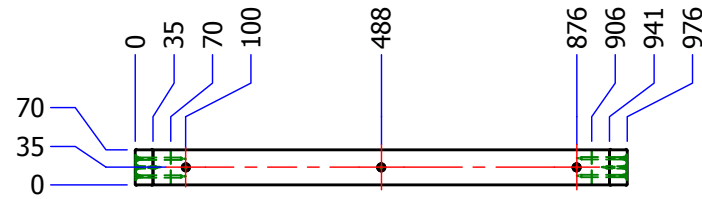

FRONT VIEW 1
(1 : 15)

A (1 : 5)

ISOMETRIC VIEW

<p>Prowler Proof GERSHWIN PTY LTD 122 BUCHANAN RD BANYO, QLD. 4014 PH: +61 7 3363 0666 FAX: +61 7 3267 5411</p>	DRAWN CAD	DATE 11/11/2012	TITLE: AS5039 - Testing	PROCESS CODE:
	CHECKED	DATE	WINDOW TIMBER - TEST FRAME	SHEET 1 OF 1
	APPR.	DATE	PART NUMBER: AS5039-SLLD FW2004	SCALE NTS
	RAW MATERIAL	MATERIAL THICKNESS	STOCK NUMBER / DESCRIPTION AS5039-SLLD FW2004	REV.
<p>* THIS DRAWING AND ITS CONTENTS ARE CONFIDENTIAL AND ARE SUBJECT TO RETURN ON DEMAND AND MAY NOT BE COPIED OR DISCLOSED TO ANY THIRD PARTY OR USED DIRECTLY OR INDIRECTLY FOR ANY OTHER PURPOSE THAN AS EXPRESSLY DETERMINED IN WRITING BY Gershwin Pty. Ltd.</p>		<p>UNLESS OTHERWISE SPECIFIED XX = • 1mm X.X = • 0.5mm XX.XX = • 0.25mm</p>	<p>ALL DIMENSIONS IN MILLIMETERS ALL THREAD TO BE METRIC COARSE ALL WELDS TO AS1554 ALL BURRS AND SHARP EDGES TO BE REMOVED</p>	<p>PROJECTION 3RD ANGLE</p>
<p>DO NOT SCALE DRAWING</p>		<p>WEIGHT: 13.72 kg</p>	<p>SHEET SIZE: A3</p>	<p>INV.</p>

REV. No	REVISION DESCRIPTION	DRAWN	DATE	APP. BY	DATE
1	REVISION HISTORY				



NATA Accredited Laboratory No: 15147



A Z U M A
Design

AS5039

TEST REPORT
(Shear test only)

Azuma Design Pty Ltd

Address: 160 Newton Rd Wetherill Park NSW 2164 Australia PH: 61(02)9604 0255 FAX: 61(02)9604 0466

SHEAR TEST REPORT

AZT Number: AZT0064.12

Date: 1st May 2012

Manufactured By: PROWLER PROOF

Sample identification: KAU 1865, Alloy Temper 6063

Surface finish: Mill finish Aperture: 60mm

Type: I

Aim: To test the sample in accordance with Section 7 of AS5041-2003-Methods of test- Security Screen Doors and Window Grilles.

Method:

- Transpose a circle of 150 mm diameter onto the infill of the test specimen. Count and record the number of chords/strands of the infill material/grille that are intersected by the circle.
- Choose a sample chord from the test specimen. For infill material of a regular, uniform design, the sample shall be a typical strand, clear of any knuckles or webs. For infill materials of irregular design and varying strand size, the thinnest structural strand intersected by the 150 mm circle shall be taken.
- Position the sample in the shear apparatus so that its orientation in relation to the cutting edges corresponds approximately to the direction of attack within a cutting tool in situ in an infill.
- Apply a load to the test sample at a rate of 19 mm/min cross-head travel and increase the load until fracture occurs.
- Record the shear force at fracture. If a double shear tool is used, the shear force recorded shall be half that which was measured.

Requirements:

- (a) The breaking force of the chords shall be not less than 30 kN.
- (b) The shear force of any chord shall be not less than 3 kN.

Test equipment:

Azuma Hydraulic test rig
Double shear tool

Azuma Design Pty Ltd

Address: 160 Newton Rd Wetherill Park NSW 2164 Australia PH: 61(02)9604 0255 FAX: 61(02)9604 0466



A Z U M A
Design

NATA Accredited Laboratory No: 15147



SHEAR TEST REPORT

Results:

Sample A

Shear	Orientation	Double shear force	Shear force (Half of double shear force)
1	Vertical	9590	4795
2	Vertical	9550	4775
3	Vertical	9330	4665
4	Horizontal	9530	4765
5	Horizontal	10350	5175
6	Horizontal	10190	5095
7	Diagonal	10060	5030
8	Diagonal	10030	5015
9	Diagonal	10260	5130
		Average =	4938.33 N

1 Number of Intersections of Strands by 150mm Dia Circle: 8

2 Average Breaking Force in Shear of one Strand (min 3kN): 4.93 kN

Multiplication of above points 1 and 2 (min 30kN): 39.50 kN

Remarks: PASSED

Azuma Design Pty Ltd

Address: 160 Newton Rd Wetherill Park NSW 2164 Australia PH: 61(02)9604 0255 FAX: 61(02)9604 0466

SHEAR TEST REPORT

Sample B

Shear	Orientation	Double shear force	Shear force (Half of double shear force)
1	Vertical	9980	4990
2	Vertical	9470	4735
3	Vertical	10210	5105
4	Horizontal	10890	5445
5	Horizontal	10320	5160
6	Horizontal	10280	5140
7	Diagonal	10360	5180
8	Diagonal	10230	5115
9	Diagonal	10390	5195
Average =			5118 N

3 Number of Intersections of Strands by 150mm Dia Circle: 8

4 Average Breaking Force in Shear of one Strand (min 3kN): 5.11 kN

Multiplication of above points 1 and 2 (min 30kN): 40.94 kN

Remarks: PASSED

CONCLUSION

From the results achieved it is evident that the sample satisfies requirement 7.6 of AS5039-2008- Security screen doors and window grilles.

SIGNATORY NAME: Rob Irwin

SIGNATURE: 

DATE: 1st May 2012

Azuma Design Pty Ltd

Address: 160 Newton Rd Wetherill Park NSW 2164 Australia PH: 61(02)9604 0255 FAX: 61(02)9604 0466



A Z U M A
Design

NATA Accredited Laboratory No: 15147



DATE: 1st May 2012

EQUIPMENTS USED TO PERFORM THE ABOVE TEST

EQUIPMENT NAME	EQUIPMENT NUMBER	√ IF USED
Tape Measure	AZTAPE0001	
1500mm Steel Rule	AZRULE0001	
Shear Test Apparatus	AZTEST0009	
Hydraulic Load Test Rig Readout	AZTEST0008	
200 mm Digital Caliper	AZCALI0010	
Knife Shear Knife	AZKNIF0001	
Knife Shear Blade	AZBLAD0001	

Azuma Design Pty Ltd

Address: 160 Newton Rd Wetherill Park NSW 2164 Australia PH: 61(02)9604 0255 FAX: 61(02)9604 0466